EL35.010



GSM Remote Control

USER'S GUIDE

CONTENTS

Notes	2
Acronyms and Definitions	2
Foreword	3
Safety Information	3
Installation Conditions	3
Environmental conditions	3
Degree of protection	3
Power supply	3
Installing the GSM EL35.010 Remote Control	4
Voltage-free contact inputs	4
Digital Inputs	4
Connecting the Expansions	5
Installing the ELES.001 Expansion	6
Installing the ELES.002 Expansion	7
Installing the ELES.004 Expansion	8
Installing the EL35.010CS Software	9
Programming Procedure	9
Command SMS	10
List of Basic Commands	10
Autorestart Function	10
List of commands with ELES.002 expansion	10
Notification SMS	11
System Requirements	12
Ratings	12
Declaration of Conformity	12

Notes

All information contained in this manual is subject to change without prior notice.

No part of this manual may be reproduced, in any form or by any means, electronic or physical, or otherwise, including photocopying or storage, for needs other than the personal use of the user, without prior written permission from ElettroTERM S.r.l.

The use, copying, modification, disassembly or transmission of the EL35.010CS software is forbidden, except for needs specifically authorized under this licence. Unless specifically authorized, all rights are held by ElettroTERM S.r.l. and/or its suppliers.

All illustrations in this manual refer to version EL35.010CS 3.0 with Windows Vista platform. For any other trademarks or products cited, reference is made to the respective owners.

Acronyms and Definitions

SMS: Short Message Service

GSM: Global Standard for Mobile Communications

LED: Light Emitting Diode

SIM: Subscriber Identification Module

Foreword

Safety Information

The GSM EL35.010 remote control is a low-power radio frequency transceiving device.

If the device is installed close to radios, televisions, telephones or electronic devices in general, it may cause interference.

Do not install the EL35.010 device close to pacemakers, auditory prostheses or medical devices in general, on aeroplanes, in the presence of inflammable gases or fumes.

The EL35.010 remote control operates by means of a radio signal, no mobile telephone operator is capable of ensuring a connection at all times. For this reason, the EL35.005 device is not suitable for use in systems providing emergency call service.

Installation Conditions

In order to ensure the operator's safety and the correct operation of the EL35.010 device, the device should be installed exclusively by qualified staff. The rules listed below should also be strictly observed.

Environmental conditions

The EL35.010 device (the instrument and all cables connected to it) should be installed in places far from:

- dust, humidity, great heat;
- direct exposure to sunlight;
- objects radiating heat;
- objects generating a strong electromagnetic field;
- liquids or corrosive chemical substances.

The EL35.010 device has been designed to operate at a temperature of between -5 °C and +45 °C (standard working temperature).

Avoid sudden changes in temperature and/or humidity.

Degree of protection

During the installation of the EL35.010 device, the following degree of protection is to be ensured:

- IP40: minimum degree of protection, which must always be guaranteed;
- IP54: protection to be guaranteed when using the device outdoors.

Power supply

Observe the following rules:

- do not use cables longer than 3 m;
- use an external power supply unit that complies with the EN 60950 Directive (electrical safety);
- do not invert the polarity of the power supply cables.

Installing the GSM EL35.010 Remote Control

The EL35.010 device has been designed to remotely control moderately complex units and systems using the functions offered by the GSM network. By using simple SMS messages you can control two relay outputs (even at the same time) and receive a notification SMS directly on your mobile telephone or on your computer via a GSM modem. Five signalling SMS messages, sent when each input opens and closes, can be associated with each input line of the device; in addition, the GSM remote control is provided with some expansion modules.

The table below shows the position of the inputs of the EL35.010 expansion.

Contact no.	Description	
1 - 5	Not used	
6	- pole	Input no. 1
7	+ pole	
8	- pole	Input no. 2
9	+ pole	
10	- pole	Input no. 3
11	+ pole	
12	- pole	Input no. 4
13	+ pole	
14	- pole	Digital input no. 5
15	+ pole	
16	- pole	Digital input no. 6
17	+ pole	
18	+ pole	12-24 VDC power supply
19	nc	
20	- pole	
21 - 29	Not Used	
30	NO	Output no. 2
31	COM	
32	NC	Output no. 1
33	NO	
34	COM	
35	NC	

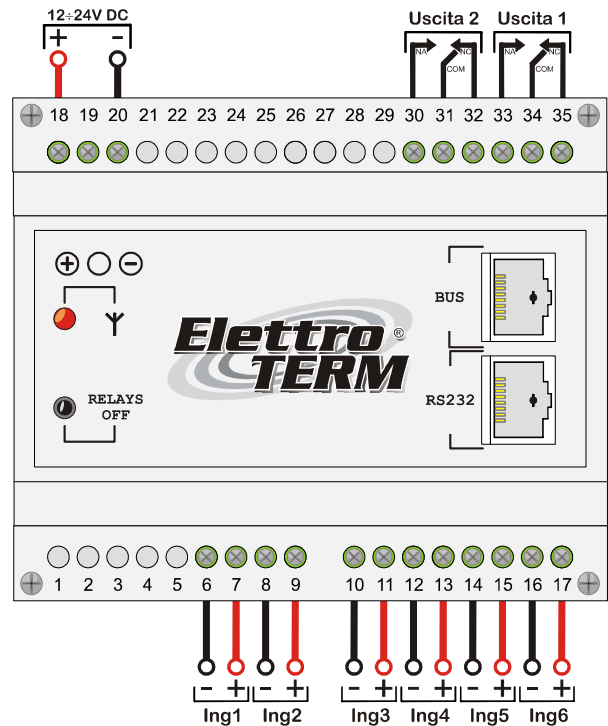

Voltage-free contact inputs

Connect the following switches:

mechanical and electromechanical with suitable ratings: 5V DC min. 500µA;

electronic with suitable ratings: 5V DC min. 500µA. Observe the polarity given alongside.

status:

ON : closed

OFF : open

Digital Inputs

Respect the polarity and the following ratings:

0 ÷ 5V DC

I_{max} = 500mA

Status:

ON: 5V DC

OFF: 0V DC

Do not use cables more than 3 m long

Connecting the Expansions

To connect the expansions to the EL35.010 unit, you must:

1. switch off the EL35.010 device;
2. connect the expansion (or the expansions) to the device using the RJ45 cable supplied in the kit;
3. program the device.

The modules must be connected to the EL35.010 device before carrying out the programming procedure (see par. "Programming Procedure") and do not require any power supply, because they are supplied directly by the BUS.

A 10 cm RJ45-RJ45 cable is provided to connect the module to the EL35.010 device; if this cable is replaced, it must not exceed a length of 1.5 metres.

Only one expansion can be connected per type. In its maximum configuration, the device may have:

1. ELES.001
1. ELES.002
1. ELES.004

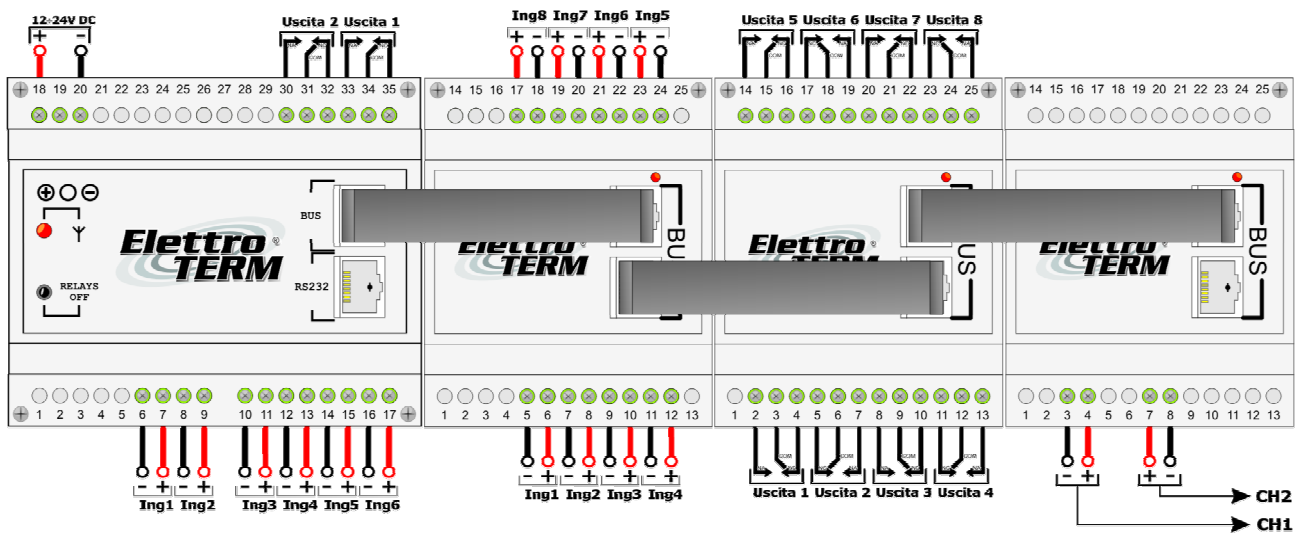

The expansions can be assembled in any order.

Installing the ELES.001 Expansion

The ELES.001 expansion module provides another 8 voltage-free contact inputs in addition to the functions of the EL35.010 device.

Using the programming software, you can associate with each input line up to five alarm SMS messages, which will be sent when each individual contact opens or closes:

1. From open contact to closed contact , sends up to 5 SMS messages
2. From closed contact to open contact , sends up to 5 SMS messages

To this type of inputs you can connect mechanical, electromechanical or electronic switches with the following requirements: 5V DC min, 50µA min.

If electronic switches are used, the polarity of the terminals must be respected.

The table below shows the position of the inputs of the ELES.001 expansion.

Contact no.	Description	
1 - 4	Not used	
5	- pole	Expansion input no. 1
6	+ pole	
7	- pole	Expansion input no. 2
8	+ pole	
9	- pole	Expansion input no. 3
10	+ pole	
11	- pole	Expansion input no. 4
12	+ pole	
13 - 16	Not Used	
17	+ pole	Expansion input no. 8
18	- pole	
19	+ pole	Expansion input no. 7
20	- pole	
21	+ pole	Expansion input no. 6
22	- pole	
23	+ pole	Expansion input no. 5
24	- pole	
25	Not used	

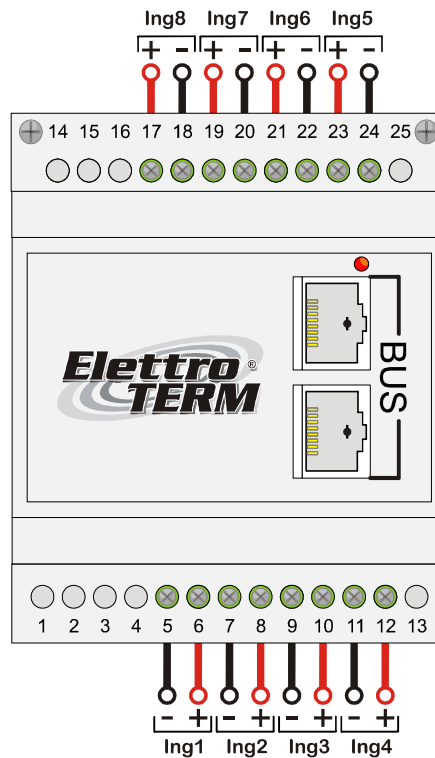

Installing the ELES.002 Expansion

The ELES.002 expansion module provides another 8 relays in addition to the functions of the EL35.010 device. The ratings of the relay outputs are:

- Monostable relay
- Contact material: silver alloy plated
- Max. initial contact resistance.: 30 mOhm
- Nominal switching capacity: 6A 250 VAC
- Max. power switching: 1500 VA
- Max. voltage: 250VAC
- Max. current: 6A

Standard	File No.	Rating
UL	E43149	6 A 277 V AC
VDE	122402ÜG	6 A 250 V AC (cosφ = 1) 1 A 250 V AC (cosφ = 0.4)
SEV	CH-99.1 10483.2A1	6 A 250 V AC (cosφ = 1)

We do not recommend exceeding a load of 2A per relay.

You can change the status of the relays present in the output expansion by sending an appropriate command SMS. The current status of the relays is saved at each change, and is restored in the event of a power failure.

The first time that the EL35.010 device is started, all the contacts of the relay outputs will be set to NC and COM (relay coils de-energized).

When the device is restarted after a power failure, the status of the relays present in the expansion is restored within about 15 sec.

The table below indicates the position of the outputs of the ELES.002 expansion.

Contact no.	Description
1	Not used
2	NO
3	COM
4	NC
5	NC
6	COM
7	NO
8	NO
9	COM
10	NC
11	NC
12	COM
13	NO
14	NO
15	COM
16	NC
17	NC
18	COM
19	NO
20	NO
21	COM
22	NC
23	NC
24	COM
25	NO

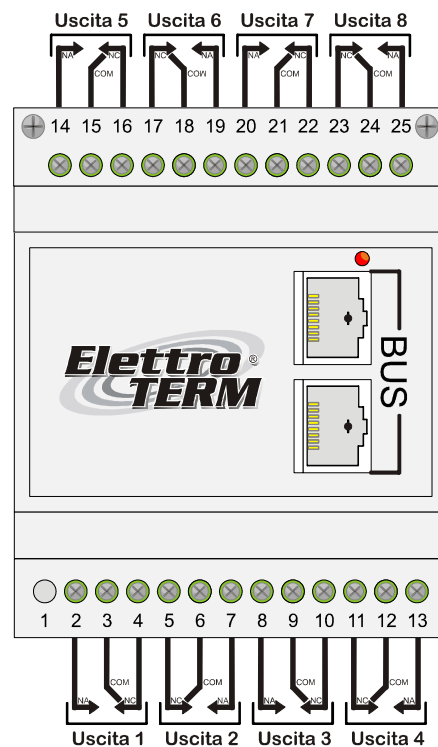

Installing the ELES.004 Expansion

The ELES.004 module is to be connected to the EL35.010 device during the programming phase (see par. "The Programming Procedure") and requires no power supply as it is supplied directly by the BUS.

In addition to the functions of the EL35.010 device, the ELES.004 offers the possibility of measuring physical parameters through two 0-10V analogue channels; in addition, it has an RTC (Real Time Clock) capable of saving the exact time at which the sample is measured and an internal temperature sensor (accuracy $\pm 1.5^{\circ}\text{C}$, precision 0.5°C).

To each of the two analogue channels (CH1 and CH2), you can assign two thresholds: TH and TL, which define three areas in which the signal may vary:

1. High critical zone
2. Standard operating zone
3. Low critical zone

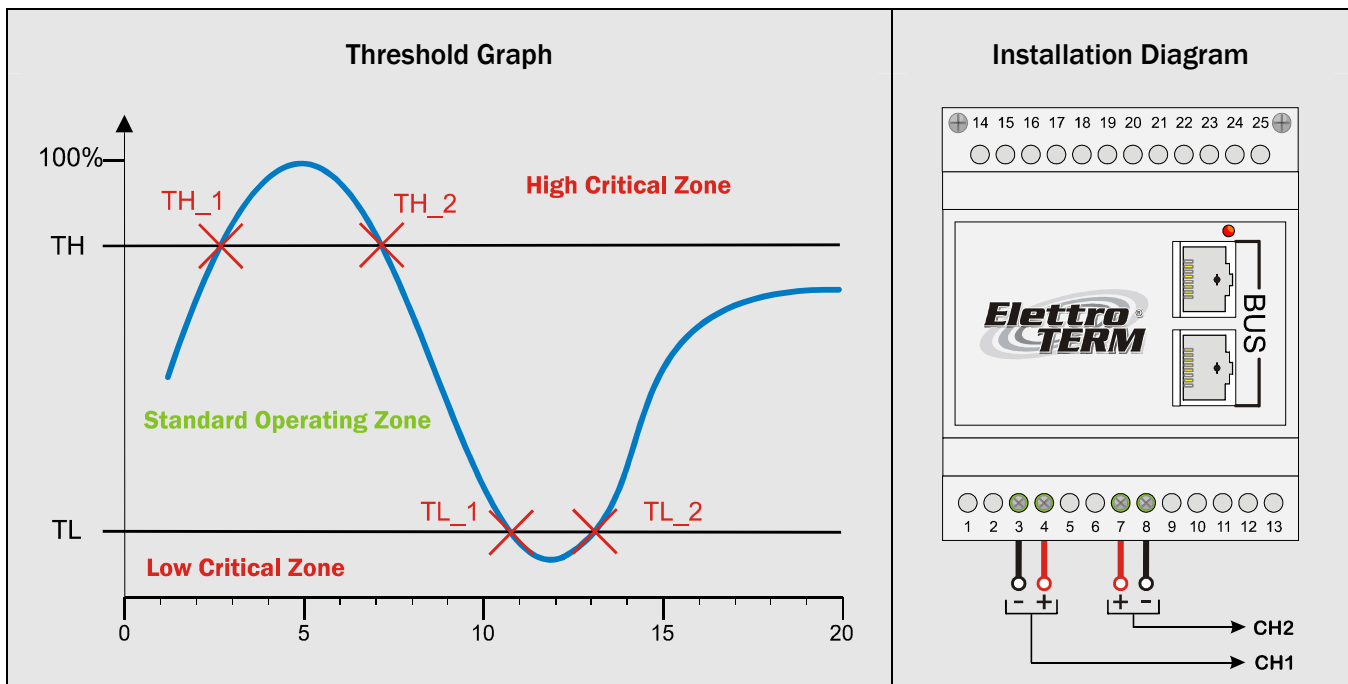

Any threshold can display two intersection points defining four different events:

- TH1: entry into high critical zone from standard operating zone;
- TH2: entry into standard operating zone from high critical zone;
- TL1: entry into low critical zone from standard operating zone;
- TL2: entry into standard operating zone from low critical zone.

Using the programming software, not only can you set the value of each threshold, but you can also associate with each event up to five alarm SMS messages, which will be sent when the device passes from one zone to another. The values of the thresholds are expressed as percentages with a resolution of 0.1%.

The values coming from the two analogue channels can be viewed by sending an SMS message requesting the status of the EL35.010 device (see par "Commands").

Installing the EL35.010CS Software

The following material (contained in the kit) is required to programme the EL35.010 device:

1. one cable for RS232 proprietary programming;
2. configuration CD.

Before proceeding to install the software, we recommend you update your own operating system.

To install the EL35.010 CS software, proceed as follows:

1. switch on the computer and start Windows;
2. insert the Mini-CD in the CD-ROM drive;
3. wait for the CD-ROM to start automatically. If automatic starting has been disabled, open My Computer and click on the CD-ROM icon with the right mouse button, then click on Autoplay;
4. click on the setup icon "Install EL35.010 CS"

Caution: when installing the EL35.010CS software it could be necessary to install Microsoft .NET Framework 3.5.

Programming Procedure

To program the EL35.010 device, proceed as follows:

1. switch off the EL35.010 device;
2. insert the SIM Card in the relative slot;
3. connect the RS232 proprietary data cable to the programming port of the device;
4. connect the RS232 data cable to the relative port on the PC;
5. **PRESS AND HOLD DOWN THE "RELAYS OFF" BUTTON** on the front panel of the device;
6. **SWITCH ON THE DEVICE;**
7. **WAIT FOR 3 FLASHES OF THE NETWORK LED, THEN RELEASE THE BUTTON.**

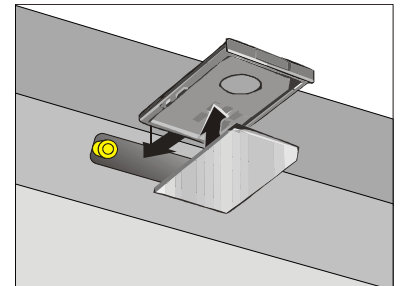

The device has entered programming mode so you may now proceed to start the programming software.

The programming software is used to enter the parameters that control the device's operation:

- **System password:** this password is to be entered in order to execute the commands (see par. "Command SMS")
- **Error notification:** if enabled, the device sends an error SMS if the contents of a command SMS are not valid

Select the COM communication port on the front bar, and then press Connect.

- Insert all desired SMS messages, save the settings to a **file** ("Save" key)
- Press the "**Load**" button to transfer the parameters to the device
- If the parameters were loaded successfully, press "**disconnect**" and close the program.
- Exit from programming mode by pressing the "**RELAYS OFF**" button

Wait for 30 seconds before sending commands to the device.

Warning: whenever parameters are to be changed, you must enter programming mode.

Command SMS

The EL35.010 device has been specially designed to receive commands via SMS messages. The commands should be sent to the phone number of the SIM Card inserted in the device. The format of a command SMS message is as follows:

PASSWORD : is the password set
: is a separator (obligatory)
COMMAND : is one of the commands listed below
NOTIFICATION : is a separator with * asterisk format

PASSWORD	#	COMMAND	NOTIFICATION
----------	---	---------	--------------

(see corresponding par.)

List of Basic Commands

Device	Command	Function	Example with password= 1234
Base	1#1	Enables output 1	1234#1#1
Base	0#1	Disables output 1	1234#0#1
Base	1#2	Enables output 2	1234#1#2
Base	0#2	Disables output 2	1234#0#2
Base	0#11	Enables outputs 1 and 2	1234#0#11
Base	0#00	Disables outputs 1 and 2	1234#0#00
Base	?	Sends the system status	1234#?

Warning: The multiple command is executed using the letter “0” as in Oliver

Autorestart Function

The Autorestart function may be used to turn off (and on again) the radio section of the device once a day. The Autorestart function can be enabled and disabled as follows.

Device	Command	Function	Example
Base	A#0	Disables the “autorestart” function	1234#A#0
Base	A#1#1	Enables autorestart function	1234#A#1#1
Base	A#?	Sends the status of the “autorestart” function	1234#A#?

List of commands with ELES.002 expansion

Device	Command	Function	Example
Base + ELES.002	1#3	Enables expansion output 1	1234#1#3
Base + ELES.002	0#3	Disables expansion output 1	1234#0#3
...
Base + ELES.002	1#10	Enables expansion output 8	1234#1#10
Base + ELES.002	0#10	Disables expansion output 8	1234#0#10
Base + ELES.002	0#11#11111111	Enables outputs 1 to 10	1234#0#11
Base + ELES.002	0#00#00000000	Disables outputs 1 to 10	1234#0#00

Warning: The multiple command is executed using the letter “0” as in Oliver

Notification SMS

The remote control answers each command sent with a "Notification" SMS. This SMS shows the information about the device and all expansions connected.

The status of the inputs and outputs is read using the following coding :

Inputs:

0 = OFF -> if input: contact open
 1 = ON -> if input: contact closed

considering that, in the base module, the first number corresponds to input no. 1 and the second number to input no. 2 and so on, up to input no. 6; while, in the expansion module, the first number will be input no. 7 and so on up to input no. 14.

Outputs:

0 = OFF -> if relay: COM-NC
 1 = ON -> if relay: COM-NO

considering that, in the base module, the first number corresponds to output no. 1 and the second number to output no. 2 ; while, in the expansion module, the first number will be output no. 3 and so on up to output no. 10.

This notification can be disabled by adding an asterisk * to the command message, e.g. :
1234#1#2*

Example of a Notification SMS:

EL35.010	+ ELES.001	+ ELES.002	+ ELES.004
Outputs: Base=00 Inputs: Base:000000 Signal:23/31	Outputs: Base=00 Inputs: Base:000000 Exp.00000000 Signal:23/31	Outputs: Base=00 Exp.=00000000 Inputs: Base:000000 Exp.00000000 Signal:23/31	13/03/08 14:20:15. Outputs: Base=00 Exp.=00000000 Inputs: Base:000000 Exp.00000000 Temp: +24.5C. Analogic: CH1:91,8% CH2:50,1%. Signal:23/31

Description of notification message

SMS	Module	Description
13/03/08 14:20:15.	ELES.004	Date and time of sample measured
Outputs:	EL35.010	Indicates the status of output nos. 1 and 2
Exp.=00000000	ELES.002	Indicates the status of output nos. 3 to 10
Inputs:	EL35.010	Indicates the status of input nos. 1 to 6
Exp.00000000	ELES.001	Indicates the status of input nos. 7 to 14
Temp: +24.5C. Analogic: CH1:91,8% CH2:50,1%.	ELES.004	Indicates the temperature detected in the switchboard and the percentage values detected by the two analogue channels.
Signal:23/31	EL35.010	Indicates the GSM signal detected by the device

System Requirements

- Operating systems supported: Windows Vista; Windows XP
- Processor: 800 MHz Pentium or equivalent (minimum); 1,5 GHz Pentium or equivalent (recommended)
- RAM: 256 MB (minimum); 512 MB (recommended)
- Hard disk: up to 600 MB of free space on the hard disk may be necessary
- CD or DVD drive
- Screen resolution: 800x600, 32 bit (minimum)

Important: make sure you have installed the Service Pack and the latest critical updates for the version of Windows in use. To look for the latest updates, select Windows Update.

Ratings

Main characteristics	<ul style="list-style-type: none"> • Enclosure for EN-50022 rail, 6 modules, UL94V-0 • Degree of protection: IP40 (if installed correctly) • max. conductor size: 2.5mm² 			
GSM section	<ul style="list-style-type: none"> • GSM Siemens TC35i module • Dual Band EGSM 900 and GSM 1800 • Certified for GSM Phase 2/2+ • Power output: <ul style="list-style-type: none"> - Class 4 (2W) for EGSM 900 - Class 1 (1W) for GSM 1800 • SMS: MO, MT 			
Power supply	<ul style="list-style-type: none"> • Supply voltage: 12V±24V DC • Current: 500mA 			
Outputs	<ul style="list-style-type: none"> • Monostable relay • Contact material: silver alloy plated • Max. initial contact resistance: 30 mOhm • Nominal switching capacity: 6A 250 VAC • Max. power switching: 1500 VA • Max voltage: 250Vac • Max current: 6A 	Standard	File No.	Rating
		UL	E43149	6 A 277 V AC
		VDE	122402ÜG	6 A 250 V AC (cosφ = 1) 1 A 250 V AC (cosφ = 0.4)
		SEV	CH-99.1 10483.2A1	6 A 250 V AC (cosφ = 1)
We do not recommend exceeding a load of 2A per relay.				
Voltage-free contact inputs	<ul style="list-style-type: none"> • Current ring: min. 5V DC, min. 500µA • Cable length < 30m 			
Digital inputs	<ul style="list-style-type: none"> • 0-5V DC 500mA - Maximum cable length: 3 metres 			
Current drawn (typical values)		Power=9V	Power=30V	
	Standby	50mA	30mA	
	Send/Receive SMS	120mA	65mA	

Declaration of Conformity

ElettroTERM Srl hereby declares that the EL35.010 device complies with the essential requirements and other applicable provisions laid down by Directive 199/5/EC and, in particular, those indicated in the

following Reference Standards:

EN 301 489-7 V1.1.1 (2000-09)

EN 301 511 V7.0.1 (2000-12)

EN 60950 (2000)

WEEE Eco-contribution paid where due - WEEE register no.: IT08020000003625